

**NUTRUSS 2.0 & 3.0** from Nuconsteel is a cost effective and extremely versatile Cold-Formed Steel (CFS) proprietary roof and floor truss system ideal for residential and commercial construction. The Nutruss 2.0 & 3.0 systems integrate all the components necessary to provide high quality CFS trusses directly from slit coil to a finished truss ready for installation. Combined with state-of-the-art engineering, design layout and manufacturing software, Nutruss 2.0 & 3.0 use an automated fabrication process that requires no jiggling, measuring, cutting, layout or stock length inventory to build only the highest quality trusses. In fact, truss fabrication is so simple, it can be manufactured on a jobsite without sacrificing quality and structural performance. Nutruss 2.0 & 3.0 integrate easily with all CFS applications along with other building construction methods such as cast-in-place concrete, pre-cast concrete, masonry and structural steel framing. All construction methods are supported with engineered truss attachment clips and structural attachment details. Nutruss material thicknesses range from 27 mil to 43 mil.



**THE NUTRUSS 2.0®  
& NUTRUSS 3.0™  
TRUSS SYSTEM**

by NUCONSTEEL

**MATERIAL AND FINISHES**

- Steel shall conform to ASTM A653 Grade SS, ASTM A1003 Structural Grade or ASTM A1039.
- Steel material minimum yield is 50,000 psi and 70,000 psi for all material thicknesses.
- Steel shall be galvanized in accordance with ASTM A924 with a G60 standard galvanized coating. For coastal areas and highly corrosive environments, a G90 galvanized coating is available.

**UL FIRE RATINGS**

Building Codes frequently require roof and floor truss framing assemblies to have a fire-resistance rating that is based on fire tests conducted in accordance with a recognized standard test. Fire rating of an assembly is a measurement that indicates how long the assembly will contain the spread of fire, smoke and temperature while maintaining structural integrity. Underwriters Laboratories (UL), Gypsum Association and Factory Mutual all have fire rated assemblies for roof and floor truss assembly.

For Nutruss 2.0 & 3.0 fire ratings visit:  
[WWW.FASTASBNN.COM](http://WWW.FASTASBNN.COM)

**NUTRUSS 2.0 & 3.0 ADVANTAGES**

- Virtually unlimited truss design – extremely versatile
- Long span capabilities
- Lightweight and easy to handle on the jobsite
- Strong weak axis performance – helps prevent damage in handling, reduces bracing requirements and provides solid footing for installers and other trades
- Truss chords and webs are in one plane
- Single chord and web profile
- Fast bolt together construction
- Virtually no scrap or waste
- Intuitive, fully integrated engineering, design and manufacturing software

**PRODUCT CERTIFICATION**

Nutruss 2.0 meets ICC technical building product and code compliance and is certified under ICC report ESR-2093.



**Environmental Data**

Nutruss 2.0 & Nutruss 3.0 truss systems use recycled steel products from Nucor, America's largest recycler, and is 100% recyclable.

## NUTRUSS 2.0 & NUTRUSS 3.0 PROPERTIES AND SPECIFICATIONS

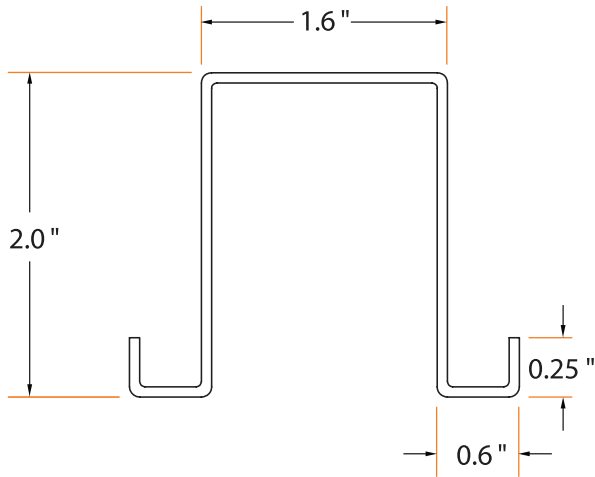

NUTRUSS 2.0

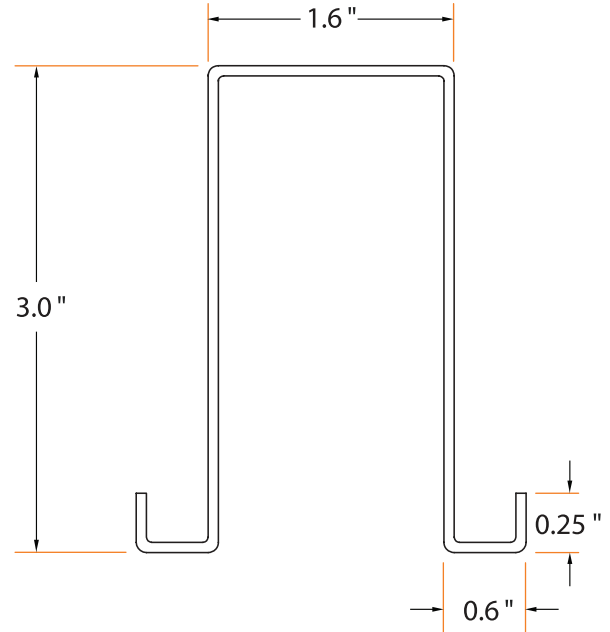

NUTRUSS 3.0

Sections	Thickness (mil) (in)	Weight (lb/ft)	Area (in <sup>2</sup> )	Gross Properties											Effective Properties (33 KSI)				Effective Properties (50 KSI)				Effective Properties (70 KSI)					
				I <sub>x</sub> (in <sup>4</sup> )	R <sub>x</sub> (in)	I <sub>y</sub> (in <sup>4</sup> )	R <sub>y</sub> (in)	S <sub>x</sub> (in <sup>3</sup> )	S <sub>y</sub> (in <sup>3</sup> )	J <sub>x</sub> 1000 (in <sup>4</sup> )	C <sub>w</sub> (in <sup>6</sup> )	R <sub>o</sub> (in)	X <sub>o</sub> (in)	Y <sub>o</sub> (in)	j <sub>y</sub> (in)	S <sub>x+</sub> (in <sup>3</sup> )	S <sub>x-</sub> (in <sup>3</sup> )	S <sub>y+</sub> (in <sup>3</sup> )	S <sub>y-</sub> (in <sup>3</sup> )	S <sub>x+</sub> (in <sup>3</sup> )	S <sub>x-</sub> (in <sup>3</sup> )	S <sub>y+</sub> (in <sup>3</sup> )	S <sub>y-</sub> (in <sup>3</sup> )					
<b>20TC22</b>	27	0.0283	0.6540	0.1936	0.1127	0.7629	0.1322	0.8264	0.1109	0.0964	0.0517	0.0414	2.0597	0.0000	1.7255	-1.9335	0.1077	0.1109	0.0922	0.0922	0.1008	0.1109	0.0877	0.0877	0.0955	0.1109	0.0840	0.0840
<b>20TC20</b>	33	0.0346	0.7996	0.2351	0.1357	0.7597	0.1585	0.8211	0.1333	0.1161	0.0938	0.0490	2.0537	0.0000	1.7223	-1.9292	0.1333	0.1333	0.1161	0.1161	0.1302	0.1333	0.1111	0.1111	0.1235	0.1333	0.1066	0.1066
<b>20TC18</b>	43	0.0451	1.0423	0.3030	0.1724	0.7543	0.2000	0.8124	0.1687	0.1476	0.2054	0.0606	2.0436	0.0000	1.7167	-1.9219	0.1687	0.1687	0.1476	0.1476	0.1687	0.1687	0.1476	0.1476	0.1678	0.1687	0.1448	0.1448
<b>30TC22</b>	27	0.0283	0.8396	0.2491	0.2950	1.0884	0.1665	0.8175	0.1960	0.1214	0.0665	0.1183	2.9981	0.0000	2.6713	-2.7906	0.1901	0.1960	0.0997	0.0997	0.1801	0.1892	0.0932	0.0932	0.1723	0.1831	0.0884	0.0884
<b>30TC20</b>	33	0.0346	1.0265	0.3029	0.3564	1.0847	0.2001	0.8127	0.2364	0.1465	0.1209	0.1409	2.9933	0.0000	2.6688	-2.7879	0.2364	0.2364	0.1286	0.1286	0.2303	0.2364	0.1201	0.1201	0.2205	0.2298	0.1137	0.1137
<b>30TC18</b>	43	0.0451	1.3380	0.3914	0.4554	1.0787	0.2534	0.8047	0.3012	0.1870	0.2654	0.1757	2.9851	0.0000	2.6645	-2.7833	0.3012	0.3012	0.1787	0.1787	0.3012	0.3012	0.1675	0.1675	0.2994	0.3012	0.1585	0.1585

**NOTES:**

1. Section properties calculated in accordance with the AISI "North American Specification for the Design of Cold-Formed Steel Structural Members" 2001 Edition with 2004 Supplement.
2. Steel shall conform to ASTM A653, ASTM A1003 or ASTM A1039.
3. Steel shall be galvanized in accordance with ASTM A924 Coating Class G60.
4. S<sub>x+</sub> is the section modulus about the x-axis, compression above the x-axis. S<sub>y+</sub> is the modulus about the y-axis, compression to the right of the axis.
5. Effective properties are based on fully braced sections.
6. Steel "Thickness" shown is the design thickness.

